

# AIRTECH

ACR35-SELV & ACR35CV-SELV



UK  
CA  
CE  
IPX7

## Installation and Wiring Instructions

### SAFETY AND GUIDANCE NOTES

All wiring to be in accordance with the current I.E.T.

Regulations, or the appropriate standards of your country and **MUST** be installed by a suitably qualified person.

The Fan is suitable for installation within Zones 1 & 2.

The Fan should be provided with a local isolator switch capable of disconnecting all poles, having a contact separation of at least 3mm.

Ensure that the mains supply (Voltage, Frequency, and Phase) complies with the rating label.

The Fan should only be used in conjunction with the appropriate Airtech products.

The fan should only be used in conjunction with fixed wiring.

When the Fan is used to remove air from a room containing a fuel-burning appliance, ensure that the air replacement is adequate for both the fan and the fuel-burning appliance.

The Fan should not be used where it is liable to be subject to direct water spray for prolonged periods of time.

Where ducted Fans are used to handle moisture-laden air, a condensation trap should be fitted. Horizontal ducts should be arranged to slope slightly downwards away from the Fan.

This appliance is not intended for use by persons (including children) with reduced physical, sensory or mental capabilities, or lack of experience and knowledge, unless they have been given supervision or instruction concerning use of the appliance by a person responsible for their safety.

Young children should be supervised to ensure that they do not play with the appliance.



## DESCRIPTION

The fan is a continuously running extract fan for kitchens, utility rooms, bathrooms and toilets. The electrical supply to this fan is 12V DC SELV from the mains controller. This means that the fan may be installed within reach of a person using a fixed bath or shower, i.e. in a nearby wall. However, for reliable operation, the fan must not be placed where it could be submerged in water or regularly exposed to direct water spray, e.g. from a shower head whether permanently fixed or movable.

The product incorporates an airflow detection system that detects the installation duct resistance and maintains the correct fan speed to achieve the preset extract flow rate (model dependant).

The incorporated LED display allows the installer to configure the fan to suit its installation. The display is also used to show the day logger and power run meter. The fan can be wall, window or panel mounted.

## ACCESSORIES

**WALL KIT** stock ref. – ESG100WALL

**WINDOW KIT** stock ref. - AWK100

**PANEL KIT** stock ref. - ACKS100

**150mm CONVERSION KIT** stock ref. - ACR-CK46

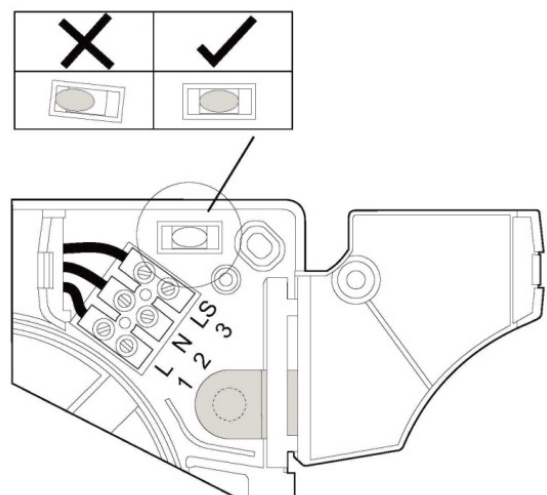
## INSTALLATION

### SITING THE CONTROLLER

1. The controller must not be installed in a shower cubicle or enclosure. It must be sited away from direct sources of water spray and out of reach (1.5m) of a person using a fixed bath or shower.
2. Site away from direct sources of heat. Ambient temperature range 0 to 40°C. Do not site in an area containing excessive levels of grease.
3. Decide where to site the controller and fan and work out the required cable runs.

### PANEL MOUNTING

1. Cut a 105mm diameter hole.
2. Remove the front panel by carefully pulling away from the fan.
3. Loosen the two self-retaining screws and remove the inner grille by carefully pulling away from the housing.
4. Using the built in spirit level bubble as an aid. Mark the screw centres through the holes in the fan back plate. Drill, plug and screw into position. Attach ducting as required for the installation.
5. Wire the fan as described in Wiring Section. Adjust any settings as required (see Setup Section).
6. After installation, ensure impeller rotates freely.
7. Replace the inner grille and tighten the retaining screws. Replace the front panel.



Open up the internal cover to access  
The spirit level bubble

## WALL MOUNTING

1. For wall mounting cut a 117mm diameter hole through the wall and insert the wall sleeve. Slope the sleeve slightly downwards away from the fan. Where necessary cut to length and cement both ends into position flush with the wall faces.
2. Fix exterior grille into position with the louvres positioned downwards.
3. Remove the front panel by carefully pulling away from the fan.
4. Loosen the two self-retaining screws and remove the inner grille by carefully pulling away from the housing.
5. Using the built in spirit level bubble as an aid. Mark the screw centres through the holes in the fan back plate. Drill, plug and screw into position.
6. Wire the fan as described in Wiring Section. Adjust any settings as required (see Setup Section).
6. After installation, ensure impeller rotates freely.
7. Replace the inner grille and tighten the retaining screws. Replace the front panel.

## WINDOW MOUNTING

1. Refer to window kit instructions supplied with the kit.

## WIRING

**WARNING:** THE FAN AND ANCILLARY CONTROL EQUIPMENT MUST BE ISOLATED FROM THE POWER SUPPLY DURING THE INSTALLATION / OR MAINTENANCE.

### IMPORTANT

The Controller **MUST** be surface mounted to allow air to freely circulate around the unit.

When installed in a loft void it **MUST NOT** be enclosed or covered with insulation.

The cross-sectional area of supply cord used should be ranged from 1 -1.5mm<sup>2</sup>.

Cable entry can be made from the rear or the side of the fan using the grommet provided.

1. Follow the wiring diagrams shown.
2. Check all connections have been made correctly and ensure all terminal connections and supply wires are securely fastened.
3. Ensure the impeller rotates and is free from obstructions.

## SETUP

### Accessing the commissioning menu

To configure the fan first remove the grille. With the grille removed the control buttons are visible (Fig.4). Do NOT isolate the fan from the power supply as configuration requires power to the fan.

### IMPORTANT



**Do NOT** attempt to remove the circuit board cover (Fig.4). This covers the high voltage power supply, preventing the risk of an electric shock.

## Display modes

When first powered on, the display will run through an initialisation sequence and then activate prism mode (cover on).

When a button is pressed, the display will go into the menu system and display as viewed without the prism.

The display will return to prism mode after 60 seconds of inactivity (i.e. no button presses).

When activating the menu, the initial button push will not change any settings.

Prism mode may also be re-activated by holding the pull-cord for 5 seconds (if applicable).

## Prism Mode




When the controller is in 'prism mode' the display will be mirrored such that the characters are shown correctly when viewed through the prism fitted in the fan cover. When activated, prism mode will run for 15 minutes, first showing the day logger then cycling between displaying:

- Airflow rate (CV model only, other models display speed setting)
- Estimated duct pressure (CV model only if CV / F-2 mode enabled)
- Current RH% (HT models only)

Calibration process will run after the first 15 minutes (if CV / F-2 mode enabled); see Advanced settings for further details.







## Menu

If the buttons are pressed the display goes from prism mode to direct view mode and menu activated. If the buttons are not pressed for 30 seconds the display reverts to prism mode.

The  (Up) button is used to increase the value of a setting, the  (Down) button is used to reduce the value of a setting and the  (Mode/Set) button is used to advance to the next menu item.



The fan has the following 'menu' modes:

- Standard (press any button from normal runtime -    )
- Advanced/Engineer (hold  +  for 5 seconds from the standard menu)
- Data-logger readout (hold  for 5 seconds from standard menu)

## Standard settings:

Display text	Configuration Option	Selections			Default
r-n	Rotate display	r-Y = display rotated		r-n = display normal	r-n
trl	Trickle speed adjustment	100mm: 0*, 5 to 30 l/s (Max limited by Boost Selection)			9l/s
bSt	Boost speed adjustment	100mm: 6 to 35 l/s (Min limited by Trickle Selection)			15 l/s
b15	Boost Overrun time	b0 to b30 – 0 to 30 minutes (0 disables overrun)			15
h70	Humidity level trigger	h40 to h90 - 40% to 90% relative humidity			70% RH
F-0	Fan Control Mode	F-0 = CV disabled, wall / window installation	F-1 = CV disabled, ducted installation	F-2 = CV Constant Volume enabled	F-0
c-n	Comfort mode	c-n = normal LS overrun		c-Y = comfort mode	c-n
unl	Enable / disable lock code	loc - lock code enabled		unl - lock code disabled (unlocked)	unl
---	Menu lock code	Up / down selects current digit, X moves to next digit.			10c
cod		To change the lock code when "cod" is displayed select the up/down buttons to select a digit then select X to move on to the next digit.			



**\*If "0" is selected, the fan switches to Intermittent mode.**

## Advanced settings:

Display text	Configuration Option	Selections		Default
A-Y	RH Ambient Response	A-Y Ambient Response enabled	A-n Ambient Response disabled	Enabled
P-Y	RH Rapid Response enable	p-Y = Rapid Response enabled	p-n = Rapid Response disabled	Y

## Settings

### Speed selection

Set trickle and boost speeds in l/s by using the  and  buttons.

**To convert m<sup>3</sup>/h to l/s, divide the m<sup>3</sup>/h by 3.6 (e.g. 54m<sup>3</sup>/h / 3.6 = 15 l/s).**

The Trickle Speed cannot be higher than the Boost selection. Therefore it might be necessary to modify the Boost selection before increasing the Trickle setting.

If "0" is selected for the trickle speed, the fan will be off until a boost signal is activated (for example via LS/ pullcord/humidity).

## **Boost time**

The boost setting allows the boost timer to be adjusted from 1-30 minutes, the default is 15 minutes. This option may also be disabled, thus removing the option from the menu and setting the overrun to 0.

## **Inbuilt Ambient Response Humidistat with Rapid Rise Detection**

The humidity threshold setting defines at what relative humidity the fan will trigger, adjustable from 40% to 90% rH. The fan increases in speed slowly between the trickle and boost speeds between the trigger %rH and +10%. The trigger point will automatically adjust if the temperature drops below 18C to prevent nuisance triggering. The fan also incorporates a rapid rise function to detect rapid rises in humidity when the ambient %rH is under the threshold setting. If a rapid rise is detected the fan will increase in speed proportionally between the trickle and boost settings until the humidity lowers again.

## **Comfort mode**

- With comfort mode disabled, the fan will go into boost as soon as an LS (Light Switch) input is detected and over-run for the set period after LS is disconnected.
- With comfort mode enabled, the fan will remain off / in trickle up to a maximum of 20 minutes. Once LS is deactivated, fan will run at boost mode for the length of time LS was present up to a maximum of 20 minutes plus the set over-run time. If the LS was activated for < 3 minutes, no boost will occur to prevent nuisance activations.

## **Fan Control Mode**

There are 3 modes for fan speed control. Wall, ducted and constant airflow/ volume (CV) mode (CV - Pro models only). In wall or ducted mode, the fan speeds are pre-determined at the factory and does not use the airflow sensor.

In CV mode (Constant Airflow/Volume), the fan will automatically adjust the fan speed to maintain the desired airflow. After the first 15 minutes of operation the fan enters calibration mode to determine the most efficient mode of operation.

## **Calibration Reset**

In some circumstances it may be necessary to reset the calibration settings (if the fan was covered to prevent dust/damage/or poor weather outside).

Reset the calibration by configuring the fan for wall or duct mode (F-0 or F-1), turn the product off and on and re-configure back to CV mode (F-2).

The fan will calibrate after 15 minutes or by holding the pullcord for 5 seconds.

## **Pullcord**

Switches the fan from trickle to boost (for boost overrun time)

- If the overrun time has been set to 0 (disabled), a default overrun duration of 5 minutes will take place.

This will override LS comfort mode, boosting the fan immediately

An activation when a Pullcord/LS (Light Switch) boost is already active shall cancel overrun timer (RH boost sources remain unaffected)

## Data Logger Menu

\* When the display is rotated the decimal point will no longer display; eg. 055 represents 5.5KWh

Display text	Description
tot run 00y 00d	Total run time in years and days
Tri run 00y 00d	Trickle speed run time in years and days
Boo run 00d	Boosted run time in days
rhu run 00d	Humidity boosted run time in days
tot EnErgy 00.0	Total Energy used displayed in KWh*
24h EnErgy 00	Energy used in last 24 hours displayed in Wh

**Cutting the power to the fan will not erase the stored data.** To reset the data, hold pullcord for 14 seconds while in the data logger menu.

### Data Examples

← Text scrolling from right to left

In this example the display is showing a total run time of 1 year and 237 days.

tot run 0 14 237d

← Text scrolling from right to left

In this example the display is showing 34Wh of energy consumption in the previous 24h.

24h EnErgy 034

### Returning to commissioning mode

A further 5 second press of the Mode button will return the fan to the commissioning menu.

## SERVICING AND MAINTENANCE

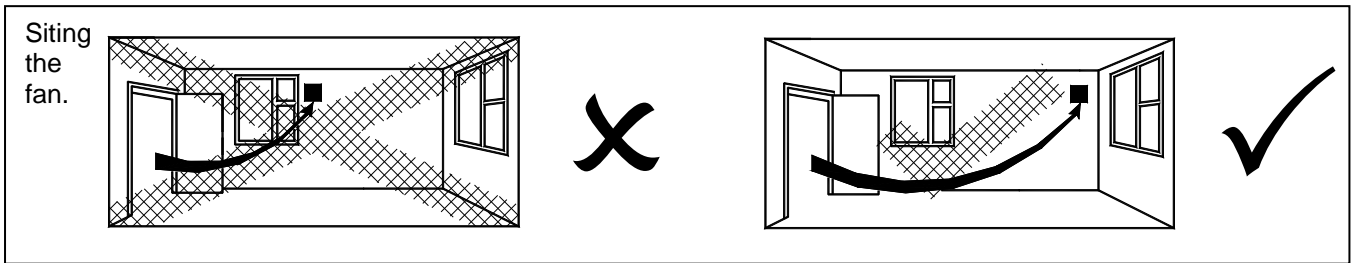


**WARNING: THE FAN AND ANCILLARY CONTROL EQUIPMENT MUST BE ISOLATED FROM THE POWER SUPPLY DURING MAINTENANCE.**

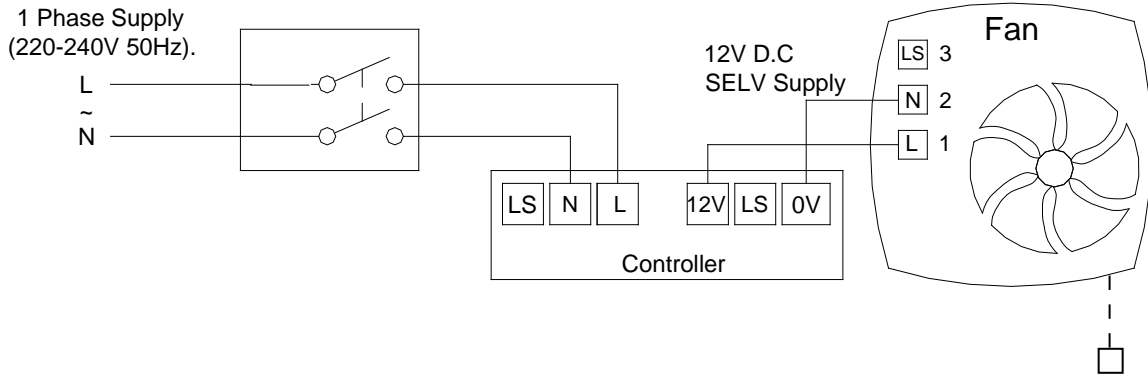
1. At intervals appropriate to the installation, the fan should be inspected and cleaned to ensure there is no build-up of dirt or other deposits.
2. Carefully pull the front panel off the inner grille. (fig. 4)
3. Wipe the inlets and front face with a damp cloth until clean. **Be careful not to push dirt into the airflow sensor. (CV model only)**

**The fan has sealed for life bearings, which do not require lubrication.**

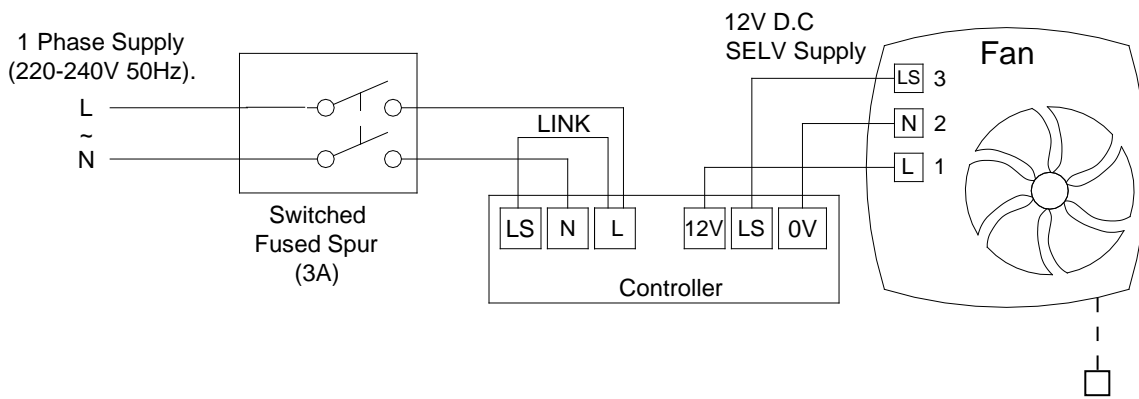




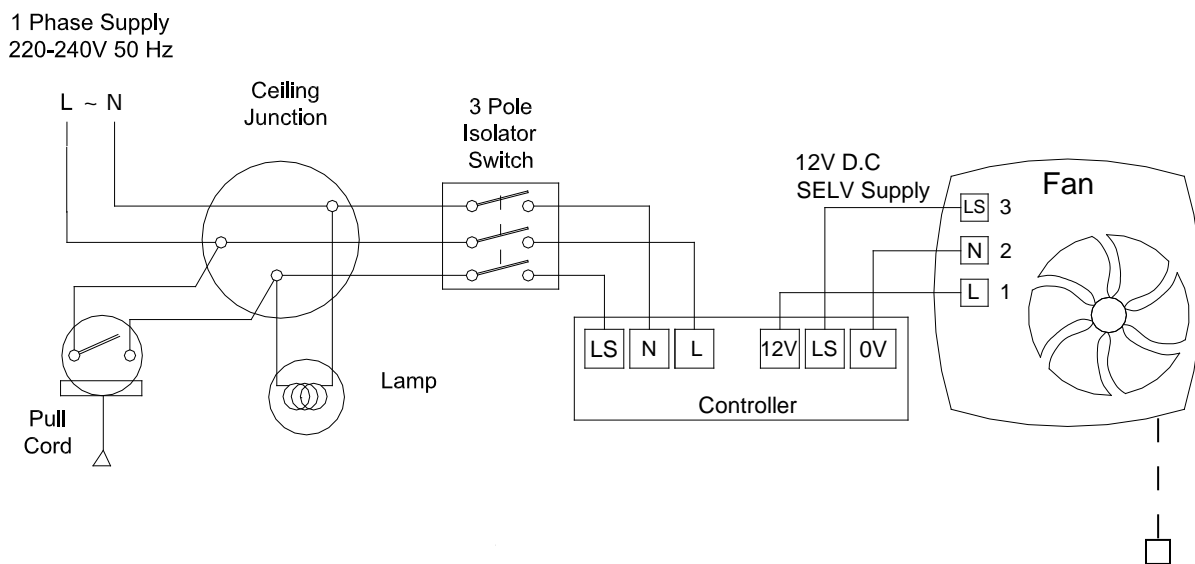
**Fig.1** Continuous trickle with pullcord boost SELV models



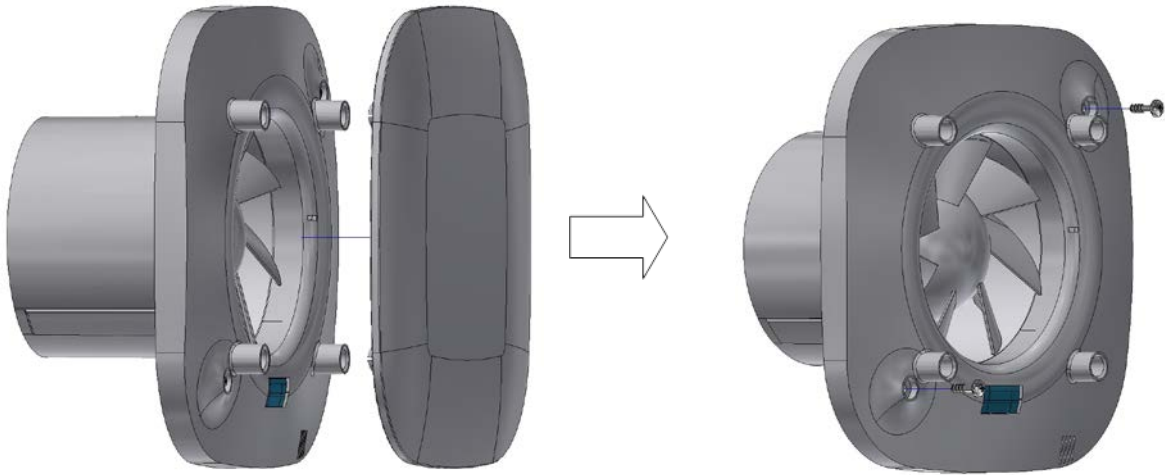
**Fig.2** Continuous boost with no trickle facility SELV models



**Fig.3** Continuous trickle with boost facility via LS or internal pullcord, SELV models

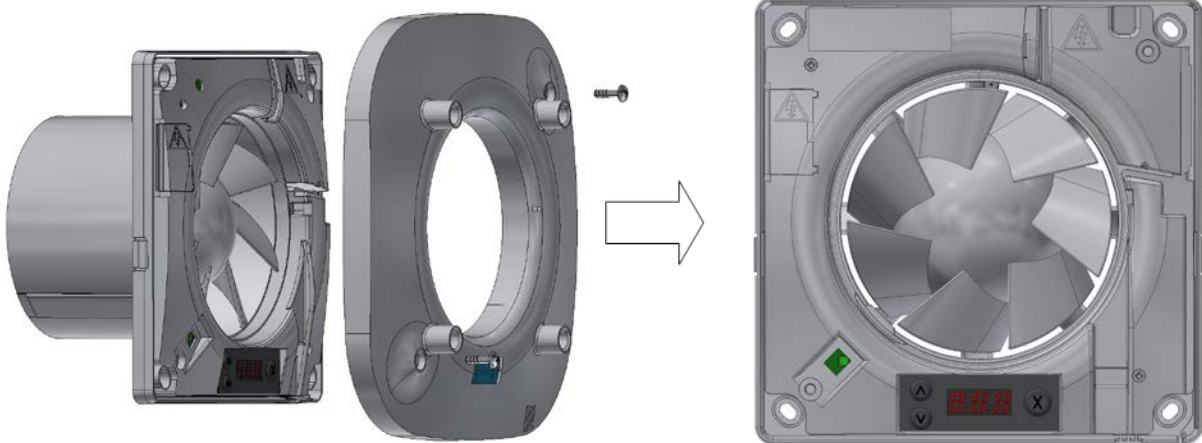


**Fig.4** Removing the grille for wiring and setting the controls

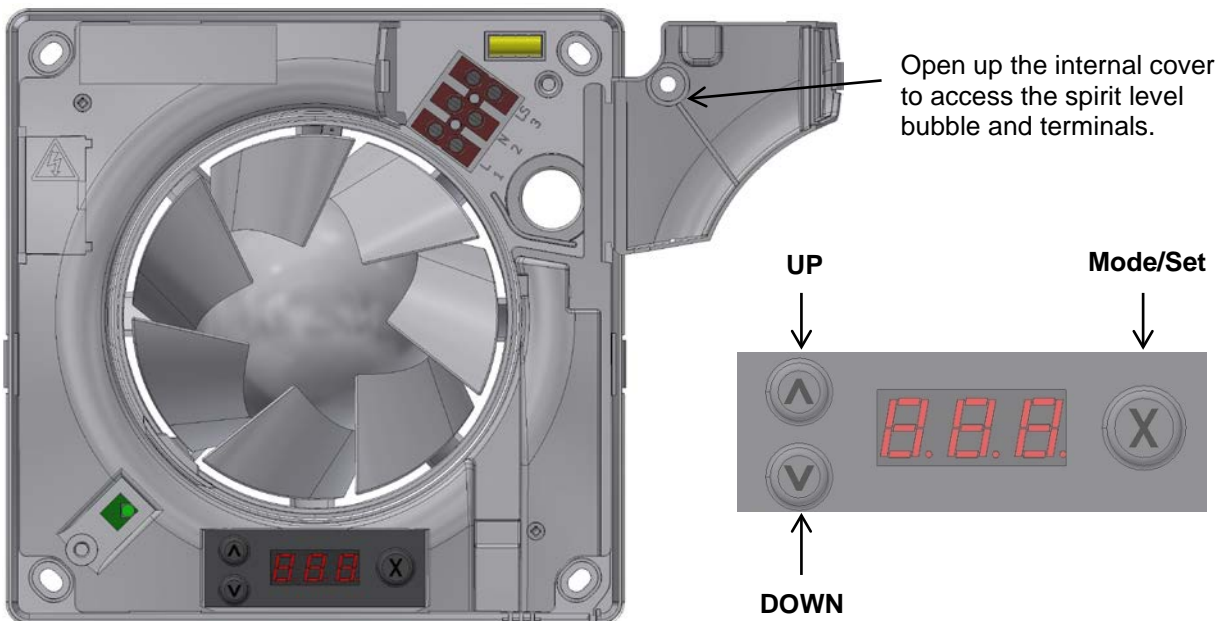


Pull front panel as shown.

Loosen screws – DO NOT REMOVE FROM GRILLE (the screws are self-retaining)



Pull inner grille away from housing as shown.



Open up the internal cover to access the spirit level bubble and terminals.

UP

Mode/Set



8.8.8



DOWN





This product should not be disposed of with household waste. Please recycle where facilities exist. Check with your local authority for recycling advice.

**AIRTECH**  
AIRTECH ENVIRONMENTAL SYSTEMS

STATHE ROAD, BURROWBRIDGE, SOMERSET, TA7 0RY  
Tel : 0800 378 017

EU Authorised Representative: Airtech solutions Sigarenmaker 5 - 5521DJ Eersel Nederland.  
[authorisedrep@airtechsolutions.nl](mailto:authorisedrep@airtechsolutions.nl)