

AIRTECH

ACR60
ACR60LV



UK
CA
CE
IPX4

Installation and Wiring Instructions

SAFETY AND GUIDANCE NOTES

All wiring to be in accordance with the current I.E.E. Regulations, or the appropriate standards of your country and **MUST** be installed by a suitably qualified person.

The Fan should be provided with a local isolator switch capable of disconnecting all poles, having a contact separation of at least 3mm.

Ensure that the mains supply (Voltage, Frequency, and Phase) complies with the rating label.

The Fan should only be used in conjunction with the appropriate Airtech products.

The fan should only be used in conjunction with fixed wiring.

When the Fan is used to remove air from a room containing a fuel-burning appliance, ensure that the air replacement is adequate for both the fan and the fuel-burning appliance.

The Fan should not be used where it is liable to be subject to direct water spray for prolonged periods of time.

Where ducted Fans are used to handle moisture-laden air, a condensation trap should be fitted. Horizontal ducts should be arranged to slope slightly downwards away from the Fan.

This appliance is not intended for use by persons (including children) with reduced physical, sensory or mental capabilities, or lack of experience and knowledge, unless they have been given supervision or instruction concerning use of the appliance by a person responsible for their safety.

Young children should be supervised to ensure that they do not play with the appliance.



This product should not be disposed of with household waste. Please recycle where facilities exist. Check with your local authority for recycling advice.

DESCRIPTION

The fan is a continuously running extract fan for kitchens, utility rooms, bathrooms and toilets. The incorporated LED display allows the installer to configure the fan to suit its installation. The display is also used to display the day logger and power run meter. The fan can be wall, window or panel/ceiling mounted.

INSTALLATION

SITING THE TRANSFORMER (SELV Model only)

1. The transformer must not be installed in a shower cubicle or enclosure. It must be sited away from direct sources of water spray and out of reach (1.5m) of a person using a fixed bath or shower.
2. Site away from direct sources of heat. Ambient temperature range 0 °C to 40°C. Do not site in an area containing excessive levels of grease.
3. Decide where to site the transformer and fan and work out the required cable runs.

PANEL/CEILING/ INTERIOR WALL MOUNTING

1. Cut a 105mm diameter hole.
2. Loosen the screw at the bottom of the grille, and then remove the grille by carefully pulling away from the housing.
3. Mark the screw centres through the holes in the fan back plate. Drill, plug and screw into position. Attach ducting as required for the installation.
4. Wire the fan as described in the Wiring section. Adjust any settings as required (see Setup section).
5. After installation, ensure impeller rotates freely.
6. Replace the grille and tighten the retaining screw.

EXTERIOR WALL MOUNTING

1. For wall mounting cut a 117mm diameter hole through the wall and insert the wall sleeve. Slope the sleeve slightly downwards away from the fan. Where necessary cut to length and cement both ends into position flush with the wall faces.
2. Fix exterior grille into position with the louvres positioned downwards.
3. Loosen the screw at the bottom of the grille, and then remove the grille by carefully pulling away from the housing.
4. Mark the screw centres through the holes in the fan back plate. Drill, plug and screw into position.
5. Wire the fan as described in Wiring section. Adjust any settings as required (see Setup section).
6. After installation, ensure impeller rotates freely.
7. Replace the grille and tighten the retaining screw.

WINDOW MOUNTING

For window mounting refer to the instructions provided with the kit.

WIRING

WARNING: THE FAN AND ANCILLARY CONTROL EQUIPMENT MUST BE ISOLATED FROM THE POWER SUPPLY DURING THE INSTALLATION / OR MAINTENANCE.

IMPORTANT

The cross-sectional area of supply cord used should be ranged from 1 -1.5mm².
The extraction fan or transformer (SELV model) is suitable for connection to 220-240V 50Hz supply.

The Transformer (SELV model only) MUST be surface mounted to allow air to freely circulate around the unit. When installed in a loft void it **MUST NOT** be enclosed or covered with insulation.

The fan is a class II double insulated product and **MUST NOT** be earthed.

1. Follow the wiring diagram shown.
2. Check all connections have been made correctly and ensure all terminal connections and supply wires are securely fastened.
3. Ensure the impeller rotates and is free from obstructions.

SETUP

Accessing the commissioning menu

To configure the fan first remove the grille. With the grille removed the control board is visible (Fig.7). Do NOT isolate the fan from the power supply as configuration requires power to the fan; removing the grille will automatically stop the impeller from spinning.

Once the fan has been commissioned please write the installation date in the box on the label provided.

Display	Setting	
r-n / r-y	Rotate display	
l-n / l-y	Intermittent Yes/No	<input type="checkbox"/>
t09	Trickle 6-13 l/s	<input type="checkbox"/>
b-n / b-y	Bathroom Yes/No	<input type="checkbox"/>
d-n / d-y	Ducted Yes/No	<input type="checkbox"/>
b01 - b30	Boost time (mins)	+ - MODE
h50 - h70	Humidity (%RH)	
c-n / c-y	Comfort mode	Pullcord Function
unl / loc	*Lock feature	Boost 1, Boost 2, Trickle
cod	*Lock code	
Installation Date		<input type="text"/>
<small>*Not available on all models</small>		

IMPORTANT



Do NOT attempt to remove the circuit board cover (Fig.7). This covers the high voltage power supply, preventing the risk of an electric shock.

With the cover removed the LED display will show the commissioning menu. There are 3 buttons located below the display; these are used to control the setup process:

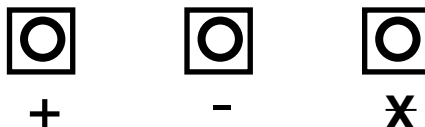

The + button is used to increase the value of a setting, the – button is used to reduce the value of a setting and the X (Mode) button moves to the next setting.

Commissioning menu structure

Display text	Installation Option	Selections		Default
r-n	Display rotation*	r-n = Default	r-y = Rotated 180°	Default
l-n or l-y	Intermittent Yes or No	l-n = No	l-y = Yes	See Model
t09	Trickle mode	t06 to t13 – 6 to 13 l/s		t09
b-n	Kitchen or Bathroom mode	b-n = Kitchen mode	b-y = Bathroom mode	Kitchen
d-n	Ducted or Wall/Window kit	d-n = wall/window mode	d-y = Ducted mode	Wall/Window
b15	Boost time	b01 to b30 – 1 to 30 minutes		15 minutes
h60	Humidity level trigger	h50 to h70 - 50% to 70% relative humidity		60% RH
c-n	Comfort mode	c-n = normal boost operation	c-y = comfort mode	No
unl	Lock feature**	unl = unlocked	loc = Locked	unl
cod	Lock code***	Set between 0 - F		cod

* This setting rotates the display only; the buttons retain their original function. For example; the mode button is on the right when in normal rotation and on the left when the screen is rotated and looking at the fan so the display is correctly orientated.

** Display: unl

Description: menu lock on or off. When locked a code is required to access the menu

Options: unl – unlocked Loc – Locked.

*** Display: cod

Description: Set the menu lock code. This is a 3 digit hexadecimal code, set between 0 - F.

Options: press up or down to start choosing the first digit then press mode to set and move to the next digit. Repeat to set the other two digits. Default override code is 999.

The table shows the settings available to commission the fan. They appear in this order. The available options and default position for each setting is also shown.

Mode	Trickle	Boost 1	Boost 2	Boost time
Kitchen	6-13 l/s	30 l/s	60 l/s	1-30 minutes
Bathroom	6-13 l/s	15 l/s	30 l/s	1-30 minutes

Settings

Installation selection

There are four different installation type settings, kitchen or bathroom and ducted or window/wall. The difference between bathroom and kitchen mode is shown above, the boost speeds are higher for kitchen applications. If the fan is installed in a ducted setup changing the fan to ducted mode will compensate for the reduced airflow due to the higher pressure of the system. During commissioning select the relevant setting for your installation.

Boost time

The boost setting allows the boost timer to be adjusted from 1-30 minutes, the default is 15 minutes.

Humidity level trigger

The humidity setting defines at what relative humidity the fan will trigger, adjustable from 50% to 70% rH.

Comfort mode

Comfort mode changes how the fan boosts. Normally the fan will go into boost as soon as an LS input is detected and over run for the set period when LS is disconnected. In comfort mode the fan will not boost until the LS has been on for 5 minutes, preventing nuisance noise. After 5 minutes of LS being on the fan will run in boost as long as LS is on and for the over run time after LS is switched off. If the LS is switched off before 5 minutes the fan will not boost. This mode does not affect the pullcord operation, pulling the pullcord will still activate boost.

Lock feature

The lock feature will prevent the unit from being adjusted after commissioning as a pass code is required to access the menu. This can be set in the menu to any 3 digit hexadecimal combination.

If the lock feature is enabled; when a button is pressed the display will show, ---. At this point enter the three digit code by first pressing + or - until the first digit is correct then press MODE to move to the next digit. Repeat until the code is entered and press MODE to enter the commissioning menu. If the code is entered incorrectly, wait until the screen switches off then press any button to begin again.

Setup example

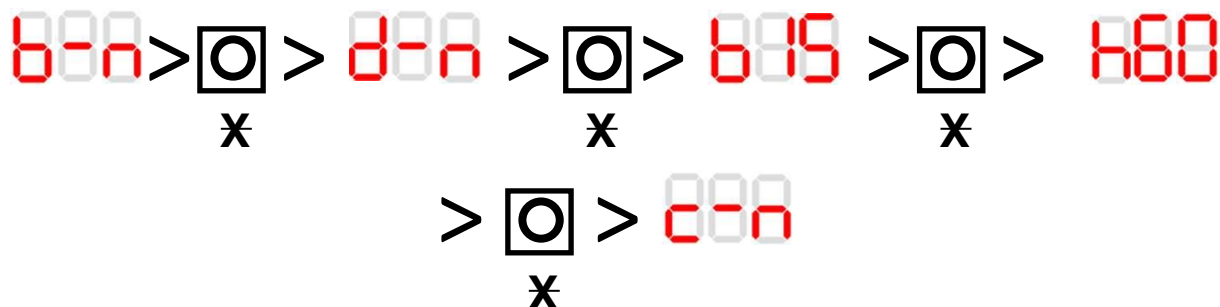

Mode button being pressed to scroll through menu. This set up is for a kitchen, in a through the wall installation with 15 minute boost timer, 60% rH set point and not in comfort mode.

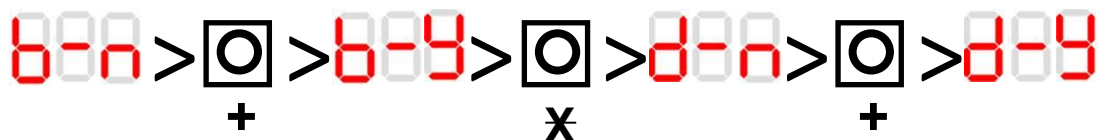

Mode and up buttons pressed to change the setting to Bathroom and ducted modes

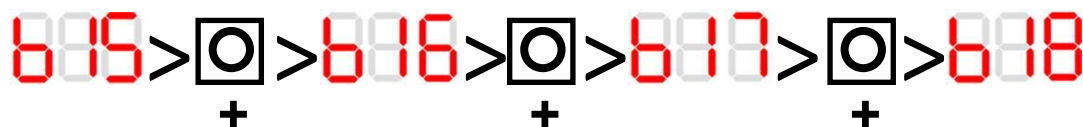

Up button pressed to change boost time from 15 to 18 minutes

Pull Cord Function

Pull → Boost 1 → Pull → Boost 2 → Pull → Trickle

Pulling the pullcord will activate boost 1, a second pull will enter boost 2 and a third pull will cancel the boost, returning the fan to trickle speed. The pullcord can be used to cancel an LS activated boost, if the fan is in an LS activated boost pulling the pullcord will first enter boost a further pull will return the fan to trickle.

Data Logger (ACR60 model)

With the fan powered up; upon removing the cover the display will automatically activate. It will display the commissioning options. Holding down the Mode button for 5 seconds will open the data logger menu. Use the mode button to move the display to the next data set.

Data Logger Menu

* When the display is rotated the decimal point will no longer display; eg. 055 represents 5.5KWh

Display text	Description
tot run 00y 00d	Total run time in years and days
Tri run 00y 00d	Trickle speed run time in years and days
Boo run 00d 00h	Boosted run time in days and hours
rhu run 00d 00h	Humidity boosted run time in days and hours
tot EnErgy 00.0	Total Energy used displayed in KWh*
24h EnErgy 00	Energy used in last 24 hours displayed in Wh

Data Examples



Text scrolling from right to left

In this example the display is showing a total run time of 1 year and 237 days.



Text scrolling from right to left

In this example the display is showing 34Wh of energy consumption in the previous 24h.

Returning to commissioning mode

A further 5 second press of the Mode button will return the fan to the commissioning menu.

SERVICING AND MAINTENANCE



WARNING: THE FAN AND ANCILLARY CONTROL EQUIPMENT MUST BE ISOLATED FROM THE POWER SUPPLY DURING MAINTENANCE.

1. At intervals appropriate to the installation, the fan should be inspected and cleaned to ensure there is no build-up of dirt or other deposits.
2. Wipe the inlets and front face with a damp cloth until clean.

The fan has sealed for life bearings, which do not require lubrication.

TROUBLESHOOTING

1. The fan continuously runs in boost:
 - a. Cause:
 - i. The room is damp or recently redecorated.
 - ii. The humidity set point is set too low.
 - b. Solution:
 - i. If the room is damp or has recently been decorated, it could take up to 2 weeks for the humidity levels to stabilise. Please leave the fan to dry out the room and after this period the fan should run normally.
 - ii. The humidity set point could be set too low. Adjust the humidity set point to a higher setting. (Setup Section)
2. The fan does not boost when the humidity is high:
 - a. Cause:
 - i. The humidity set point is set too high.
 - b. Solution:
 - i. Adjust the humidity set point to a lower setting. (Setup Section)
3. Water is dripping out of the fan when installed in a ceiling:
 - a. Cause:
 - i. This is caused by condensation forming on the inside of the ducting and dripping out of the fan inlet.
 - b. Solution:
 - i. This is normal and the fan is designed to handle condensation build up. However a condensation trap connected immediately after the fan will help to prevent water dripping into the room.

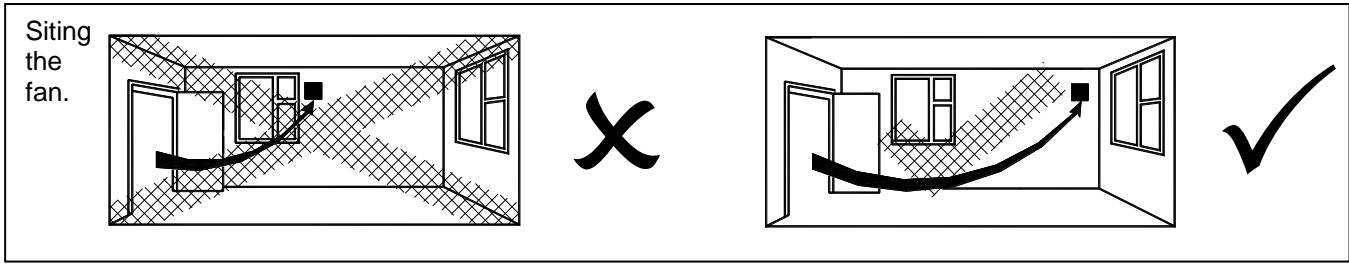

Fig.1 Continuous trickle with boost via pull cord. (The fan is internally fused)

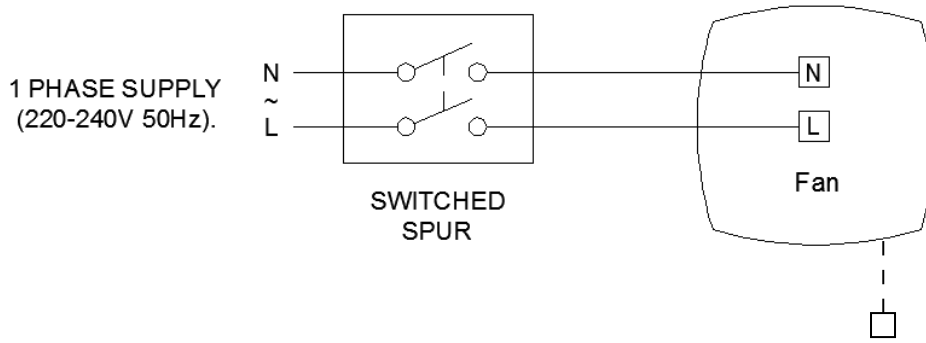

Fig.2 Continuous boost 1 with no trickle facility. (The fan is internally fused)

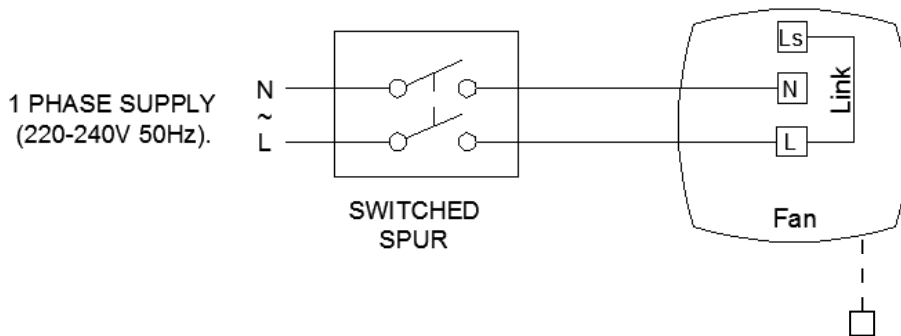

Fig.3. Continuous trickle with boost facility. (The fan is internally fused)

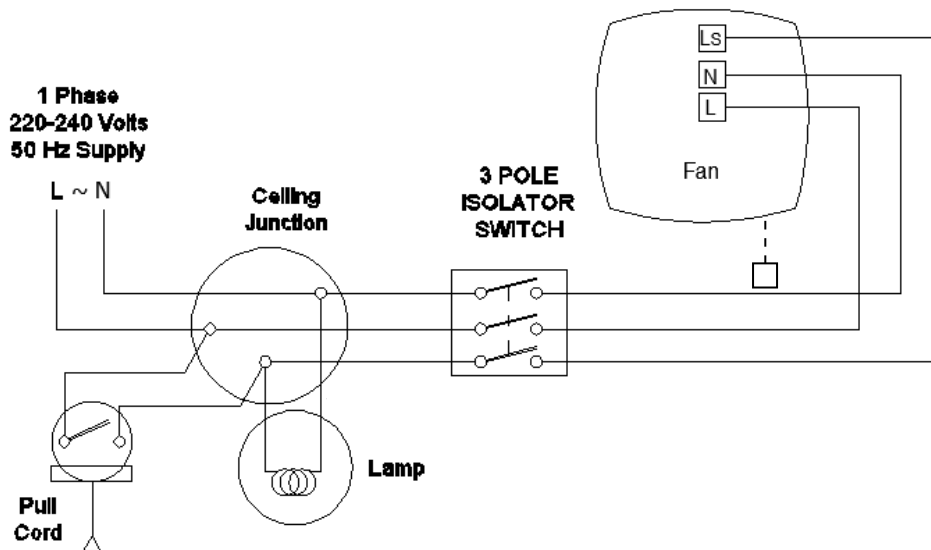

Fig.4 Continuous trickle with pullcord boost ACR60LV model

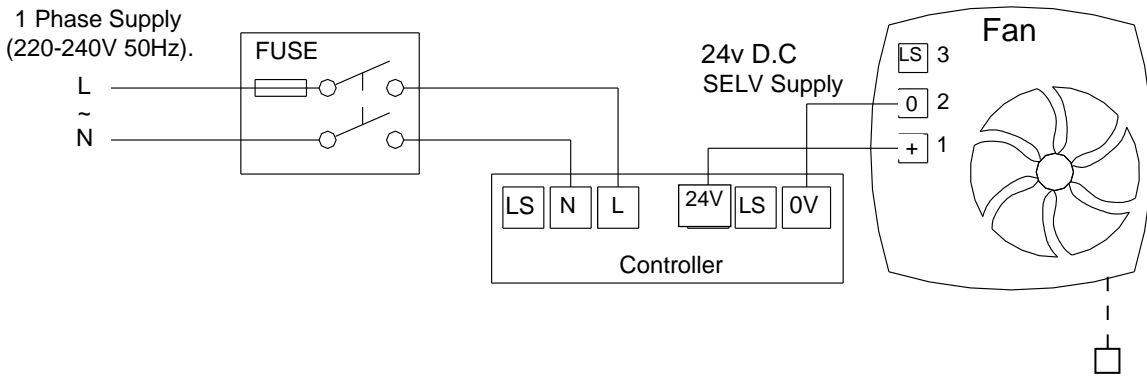

Fig.5 Continuous boost 1 with no trickle facility ACR60LV model

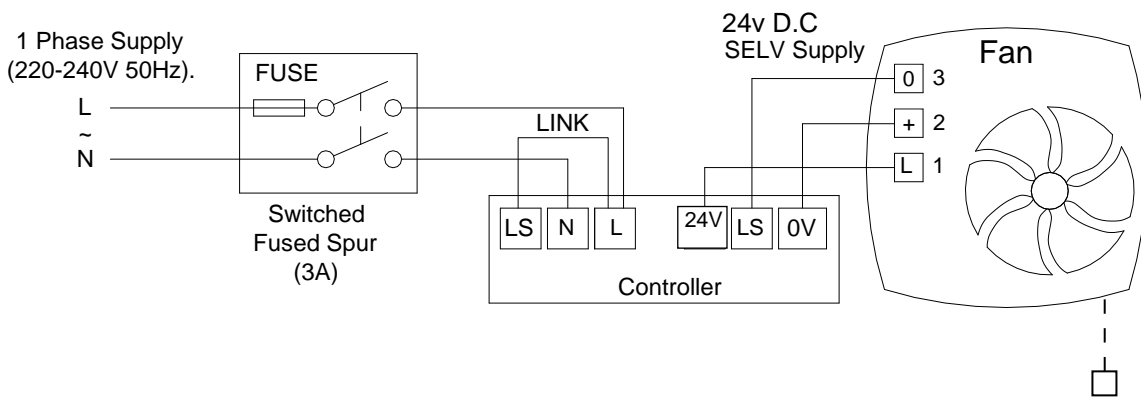

Fig.6 Continuous trickle with boost facility via LS or internal pullcord, ACR60LV model

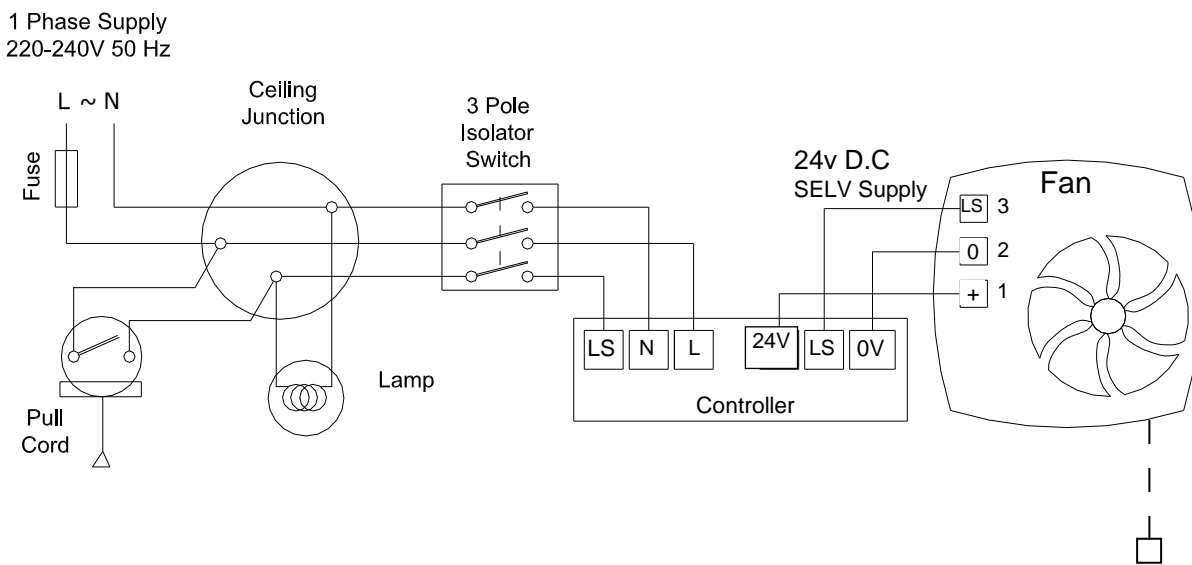
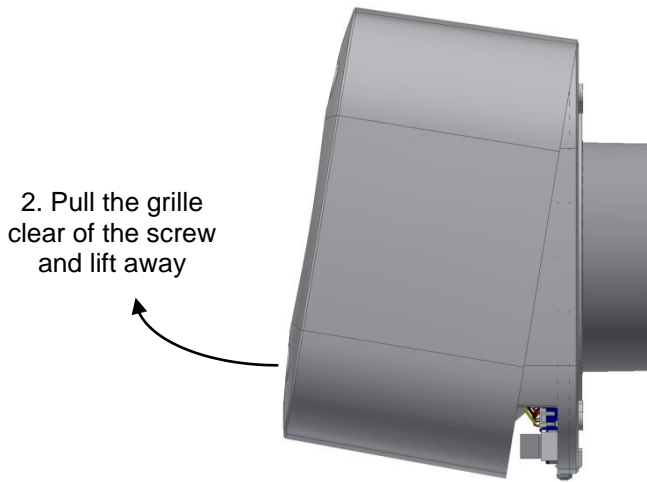
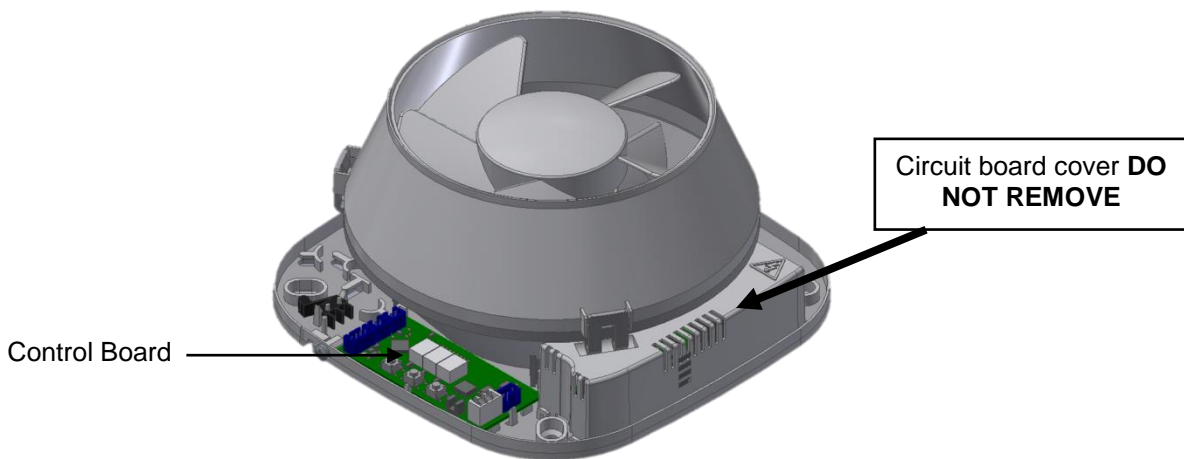

Fig.7. Removing the grille for wiring and setup



Note: ACR60 models; do **NOT** attempt to pull off the flat front cover.

1. Loosen the screw at the bottom of the grille



Display

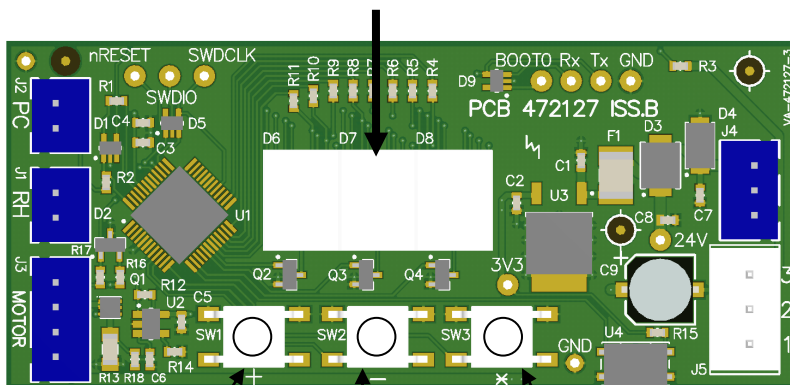

INCREASE
Value

REDUCE
Value

MODE
Button



STATHE ROAD, BURROWBRIDGE, SOMERSET, TA7 0RY
Tel : 0800 378 017

EU AUTHORISED REPRESENTATIVE: AIRTECH SOLUTIONS, BEDRIJVENWEG, 17 7442 CX, NIJVERDAL, NEDERLAND
Email: authorisedrep@airtechsolutions.nl